

🕒 Z400-SR FLOOR DRAIN STABILIZER RING



Patented

ENGINEERING SPECIFICATION

Zurn Z400-SR floor drain stabilizer ring features Dura-Coated cast iron ring with four 1/4"-20 x 1/2" securing screws, four 1/4"-20 x 1-1/2" securing screws, and four 3/8"-16 x 7" long threaded rods. Stabilizer ring is designed to accommodate 2", 3", and 4" pipe and used with 8-3/8" diameter (Z415) drain body.

A Pipe Size inches [mm]	Approximate Weight lb [kg]
2 [51], 3 [76], 4 [102]	3 [1]

PREFIXES	DESCRIPTION	A PIPE SIZE	LIST PRICE
Z400-SR*	Stabilizer Ring	2", 3", 4"	121.00

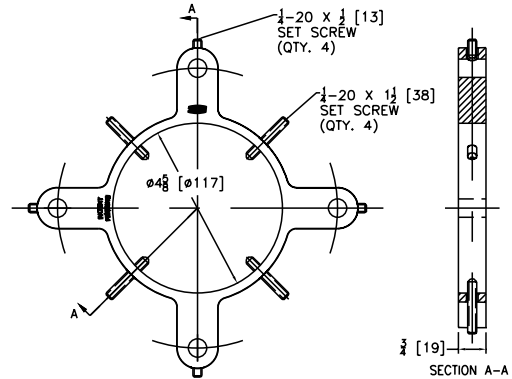

Z400-U ADJUSTABLE STRAINER EXTENSION



ENGINEERING SPECIFICATION

Zurn Z400-U "Type U" adjustable strainer extension is used as a drain extension, but also as a hub drain.

Product Designation	Size inch [mm]	Approximate Weight lb [kg]
-U	3-1/2 [89]	2 [1]

PREFIXES	DESCRIPTION	A PIPE SIZE	LIST PRICE
Z400-U*	D.C.C.I.	3-1/2"	140.00
ZN400-U	Cast Nickel Bronze Body	3-1/2"	263.00
BEST SELLER			LIST PRICE
Z400-U			140.00

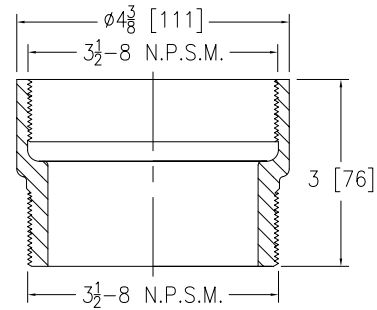

🕒 Z400-18 LEVELING RING



ENGINEERING SPECIFICATION

Zurn Z400-18 with Dura-Coated cast iron tapered ring can level Z415 clamp collar for 1/8" out-of-level conditions.

PREFIXES	DESCRIPTION	LIST PRICE
Z400-18*	Leveling Ring	37.00

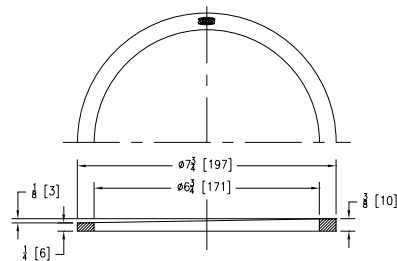

Supplied By:



877-903-7246

www.commercialplumbingsupply.com

*Regularly furnished unless otherwise specified.

Items designated as Best Sellers are most specified and are generally in stock for shipment.

🕒 This symbol denotes a product that is engineered to reduce installation and rework time.

For additional product information, please visit www.zurn.com